

## 2.3 REMOLQUE VERTICAL DE UN SINFÍN CON CINTA DE DESCARGA MODELO MV



### CINTA TRASERA

- Sinfín vertical con cuchillas dentadas, con rascador reforzado en EN HARDOX
- Cuatro células de pesaje Ø 54 mm
- 2 contracuchillas regulables
- Escalera con acceso por ambos lados
- Báscula programable (15 raciones, 15 ingredientes)
- Mandos a distancia flexibles
- Cambio de velocidad (16-34 vueltas /min) 80CV
- Pie mecánico
- Cardan simple
- Enganche atornillado regulable en altura
- Cinta de descarga trasera
- Sin central hidráulica. Conexión por enchufes rápidos al tractor. (Ver código V)
- Ruedas simples:  
30x11,5 - 14,5

MODELO	CAPACIDAD	POTENCIA C. V.	CÓDIGO: CINTA INOX / CINTA PVC	CÓDIGO: CINTA ACERO
<b>MV-8 DT</b>	8 m <sup>3</sup>	60	6008-12 / 6008-42	6008-22
<b>MV-10 DT</b>	10 m <sup>3</sup>	70	6010-12 / 6010-42	6010-22
<b>MV-12 DT</b>	12 m <sup>3</sup>	75	6012-12 / 6012-42	6012-22
<b>MV-14 DT</b>	14 m <sup>3</sup>	80	6014-12 / 6014-42	6014-22
<b>MV-16 DT</b>	16 m <sup>3</sup>	90	6016-12 / 6016-42	6016-22
<b>MV-18 DT</b>	18 m <sup>3</sup>	100	6018-12 / 6018-42	6018-22

## Especificaciones técnicas MV cinta trasera

MODELO	CAPAC. m³	POTENCIA C.V.	REDUCTOR	NEUMÁTICOS	A mm	B mm	C mm	D mm	E mm	F mm	TARA kgr.
<b>MV-8 DT</b>	8	60	PGA 1602	30x11,5 - 14,5	5.659	3.859	2.300	1.875	2.556	583	3.690
<b>MV-10 DT</b>	10	70	PGA 1602	30x11,5 - 14,5	5.659	3.859	2.300	1.875	2.676	583	3.790
<b>MV-12 DT</b>	12	75	PGA 1602	30x11,5 - 14,5	5.659	3.859	2.435	1.875	2.833	583	4.065
<b>MV-14 DT</b>	14	80	PGA 1602	445/45- 19,5	5.659	3.859	2.435	2.042	3.143	693	4.170
<b>MV-16 DT</b>	16	90	PGA 1602	8/15/15 Gemelas (*)	5.682	3.859	2.437	2.120	3.293	583	4.295
<b>MV-18 DT</b>	18	100	PGA 2102	445/45 - 19,5	5.759	3.859	2.600	2.242	3.403	693	4.870

(\*) ATENCIÓN Ruedas gemelas

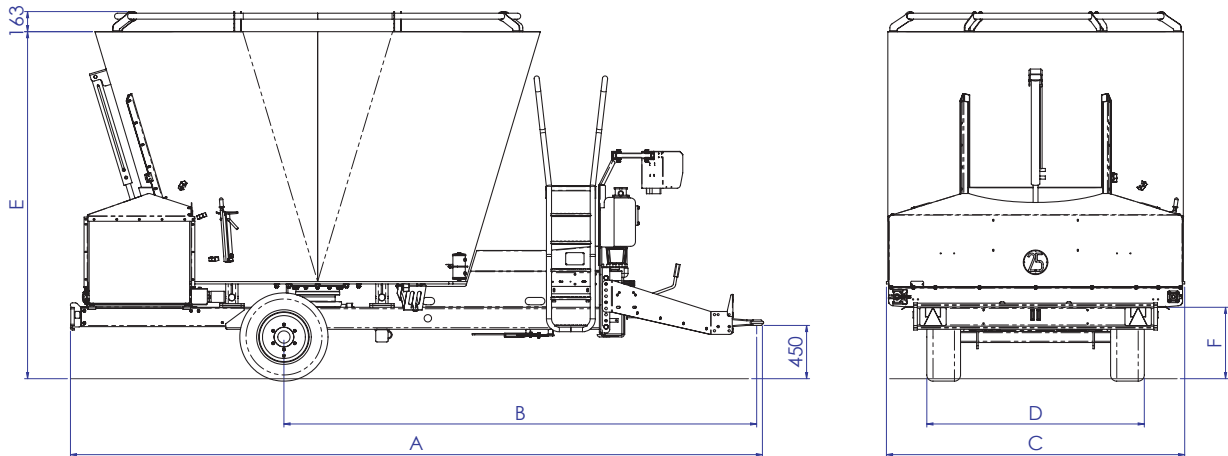

## Altura de descarga

MODELO	&	NEUMÁTICOS	mm	
			L = 1.000	
			H (mm)	D (mm)
<b>MV-8</b>	30°	30/11.5 - 14.5	1.083	2.525
		400/60 - 15.5	1.215	
		GEM. 8.15.15	1.078	
		445/45 - R 19,5 - 220	1.218	
<b>MV-10</b>	30°	30/11.5 - 14.5	1.083	2.525
		400/60 - 15.5	1.215	
		GEM. 8.15.15	1.078	
		445/45 - R 19,5 - 220	1.218	
<b>MV-12</b>	30°	30/11.5 - 14.5	1.083	2.525
		400/60 - 15.5	1.215	
		GEM. 8.15.15	1.078	
		445/45 - R 19,5 - 220	1.218	
<b>MV-14</b>	30°	445/45 - R 19,5 - 220	1.193	2.690
		GEM. 8.15.15	1.058	
<b>MV-16</b>	30°	445/45 - R 19,5 - 220	1.328	2.770
		GEM. 8.15.15	1.193	
<b>MV-18</b>	30°	445/45 - R 19,5 - 220	1.193	2.890
		GEM. 8.15.15	1.058	

